

VEHICLE INSTALLATION INSTRUCTIONS
 FORD 4 X 4: 1992 - 1997 F250 HD - F350

Hiniker Company
 58766 240th St.
 P.O. BOX 3407
 Mankato, MN 56002

INSTRUCTION SHEET NO: 25010307 REV C

May 25, 2004

IMPORTANT: Read the Snowplow Operator's Manual before assembling this kit.

MINIMUM VEHICLE RECOMMENDATIONS	REAR BALLAST - 500 lbs. for 7-1/2' blade, 600 lbs. for 8' and over blades when plow is attached. Secure Weight Behind Rear Wheels.
MFR Snowplow Prep Package HD Alternator HD Battery HD Front Springs	

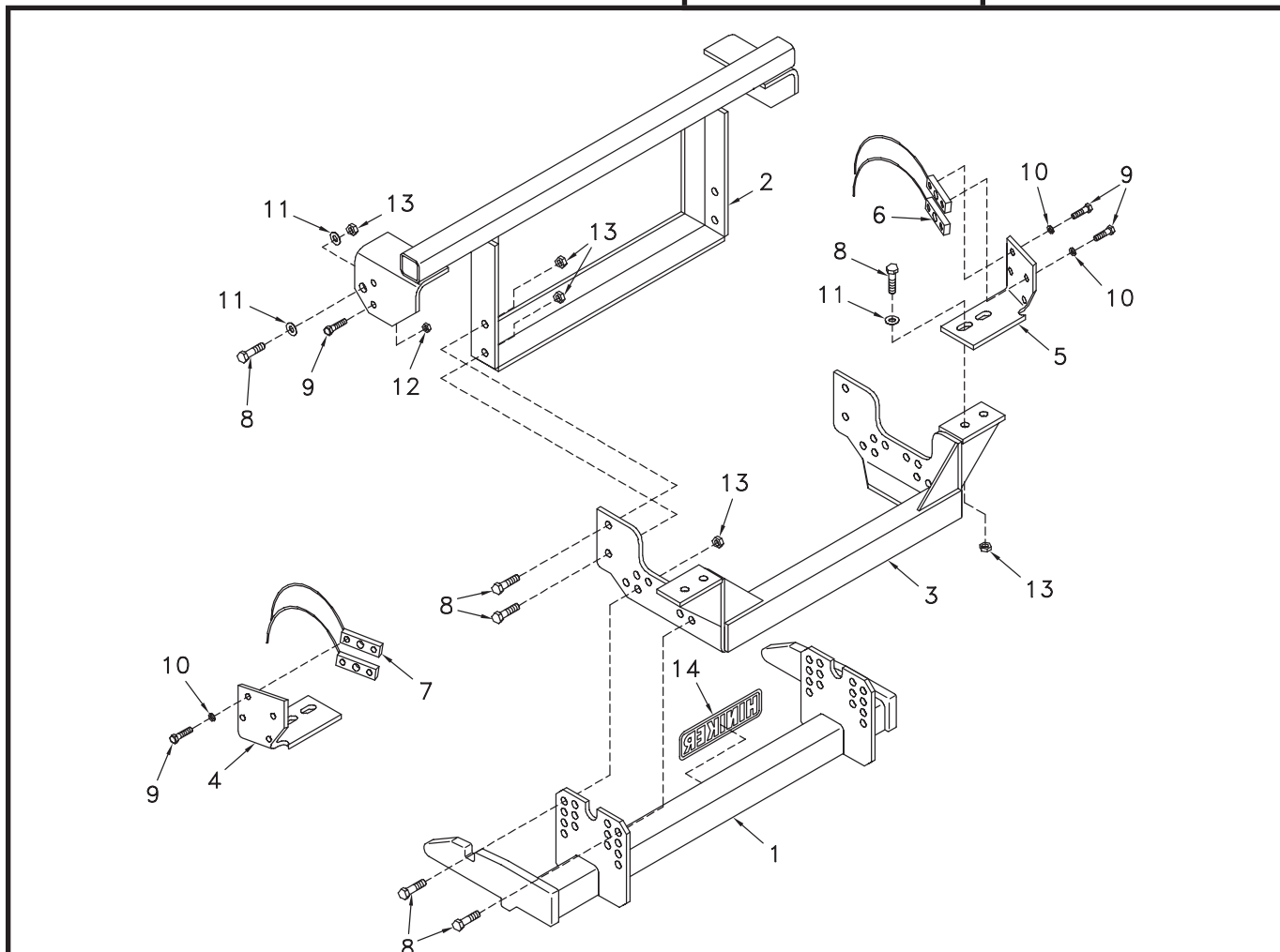

Mount Kit No. 25010255

DWG NO. 3063B

REF. NO.	PART NUMBER	DESCRIPTION	QTY.	REF. NO.	PART NUMBER	DESCRIPTION	QTY.
1	25010177	Prong Weldment	1	9	950-001-125	Hex Head Cap Screw 1/2-13 X 1 1/2 Gr. 5	12
2	25010179	Front Bracket Weldment	1	10	952-001-004	Lock Washer, 1/2 Inch	8
3	25010485	Mount Frame Weldment	1	11	952-002-007	Flat Washer, 5/8 Inch	8
4	25010478	LH Bracket	1	12	951-003-009	Lock Nut 1/2-13 Nylon Insert	4
5	25010479	RH Bracket	1	13	060756	Lock Nut 5/8-11 Nylon Insert	18
6	25010173	RH Nut Weldment	2	14	25010008	Hiniker Decal	1
7	25010174	LH Nut Weldment	2		25011167	Bolt Bag	
8	950-001-132	Hex Head Cap Screw 5/8-11 X 1 3/4 Gr. 5	18				

All hardware should be tightened only enough to ensure safety during assembly. Fully tighten all hardware after entire assembly is completed.

GRADE 5 TYPE B & F LOCK NUT TORQUES

Size	Ft.-lbs.	N-m
5/16"	13-18	17-25
3/8"	23-33	31-44
1/2"	58-82	79-112
5/8"	117-165	158-223

GRADE 5 BOLT TORQUES*

Size	Ft.-lbs.	N-m
1/4"	8-12	11-16
3/8"	29-41	39-56
1/2"	73-103	99-140
5/8"	146-206	198-279

* applications without lock nuts

1. Remove the front bumper from the truck.

Clamp LH and RH brackets to the outside and bottom of the vehicle frame, and against the protruding rivet from the bottom of the rails. On trucks without protruding rivets, locate mounts to front edge of 1/2 inch holes in bottom of vehicle side rails.

If the truck doesn't have either a rivet or hole in the bottom of the side rails, clamp the LH and RH brackets to the vehicle with the leading bottom hole in the bracket at the back of the slot shown in photo 3499.

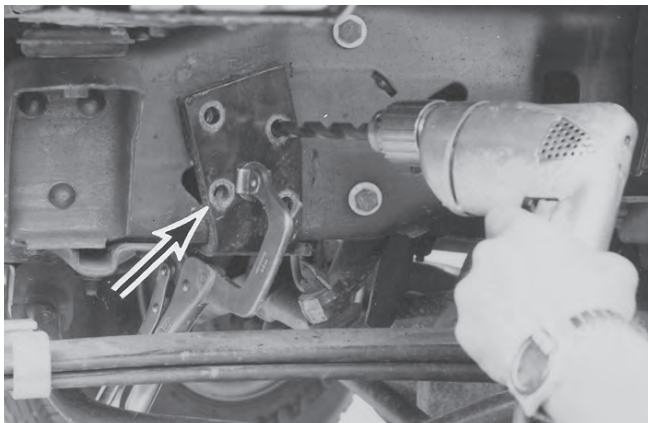

PHOTO NO. 3499

Drill 17/32 inch diameter holes in each frame rail through existing holes in the bracket.

2. Insert LH and RH nut bars into vehicle frame to match drilled holes.

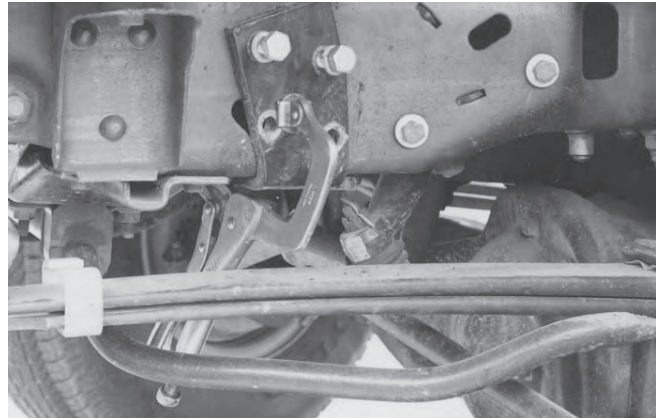

PHOTO NO. 3500

Bolt brackets in place with 1/2 inch X 1 1/2 inch hex bolts and lock washers.

3. Carefully lift mount frame weldment into position under the radiator and bolt to LH and RH brackets with 5/8 inch X 1 3/4 inch hex bolts with flat washers and lock nuts, as shown in Photo No. 3502.



PHOTO NO. 3501

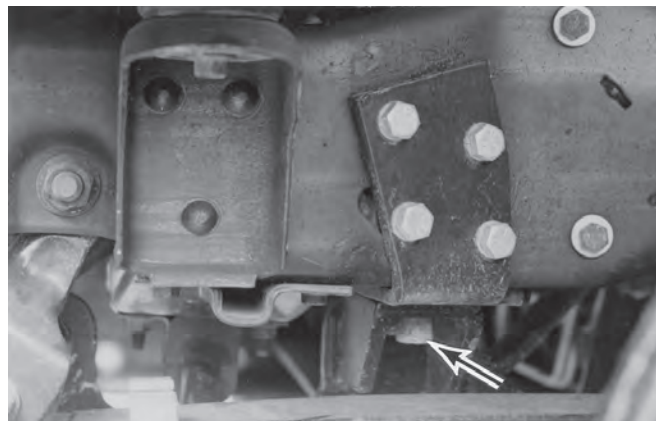

PHOTO NO. 3502

4. Slide the front bracket weldment over top of the vehicle rails.

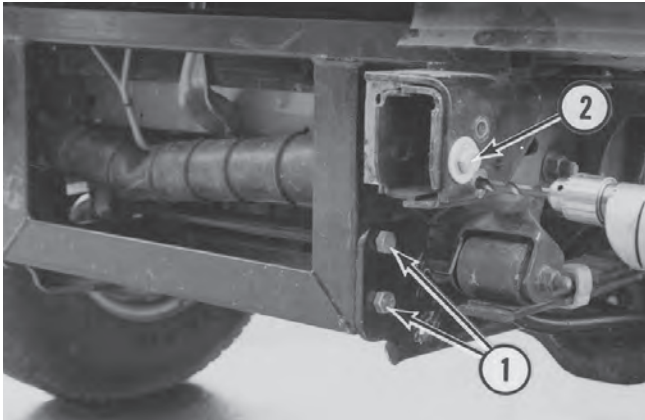



PHOTO NO. 3503

Bolt the front bracket weldment to the mount frame weldment with 5/8 inch X 1 3/4 inch hex bolts through the holes in the mount frame at location 1.

 **CAUTION: A minimum 3/8 inch clearance must be maintained between the pitman arm of the truck and the rear surface of the mount frame weldment.**

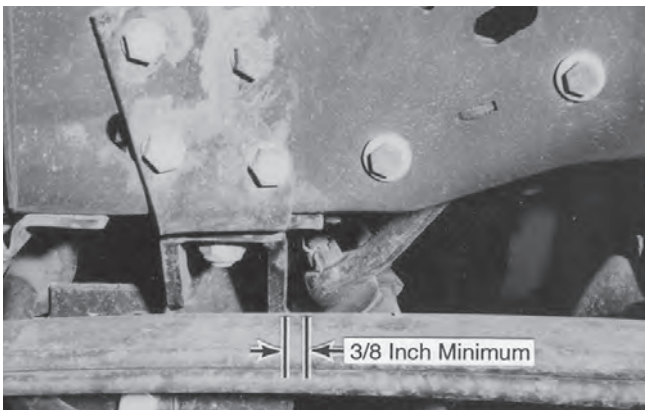

PHOTO NO. 3580

On some vehicles a 21/32 inch diameter hole must be drilled in the vehicle frame through the hole in the mount frame at location 2 in photo 3503 to obtain clearance with the pitman arm.

Install 5/8 inch X 1 3/4 inch hex bolts through front holes of bracket and holes in vehicle frame at location 2, using a flat washer under each bolt head and lock nut.

Drill two 17/32 inch diameter holes in each rail through existing holes in the bracket and install 1/2 inch X 1 1/2 inch hex bolts. As shown in Photo No. 3503.

5. Bolt the prong weldment to the mount frame weldment with 5/8 inch X 1 3/4 inch hex bolt through the holes at location 3.



PHOTO NO. 3504

Bottom edges of the prongs should measure about 10 inches above the ground. Ideally, the prongs should lift the plow frame slightly when attaching the plow.

6. Fully tighten all hardware and reattach the front bumper onto the truck with original hardware.



PHOTO NO. 3505