

VEHICLE INSTALLATION INSTRUCTIONS FOR:
CHEV/GMC 2003 & NEWER
4500/5500 4x2

Hiniker Company
58766 240th St.
P.O. Box 3407
Mankato, MN 56002

INSTRUCTION SHEET NO: 25012123

JULY 10, 2006



IMPORTANT: Read the Snowplow Operator's Manual before assembling this kit.

REAR BALLAST - As required to meet front GAWR.

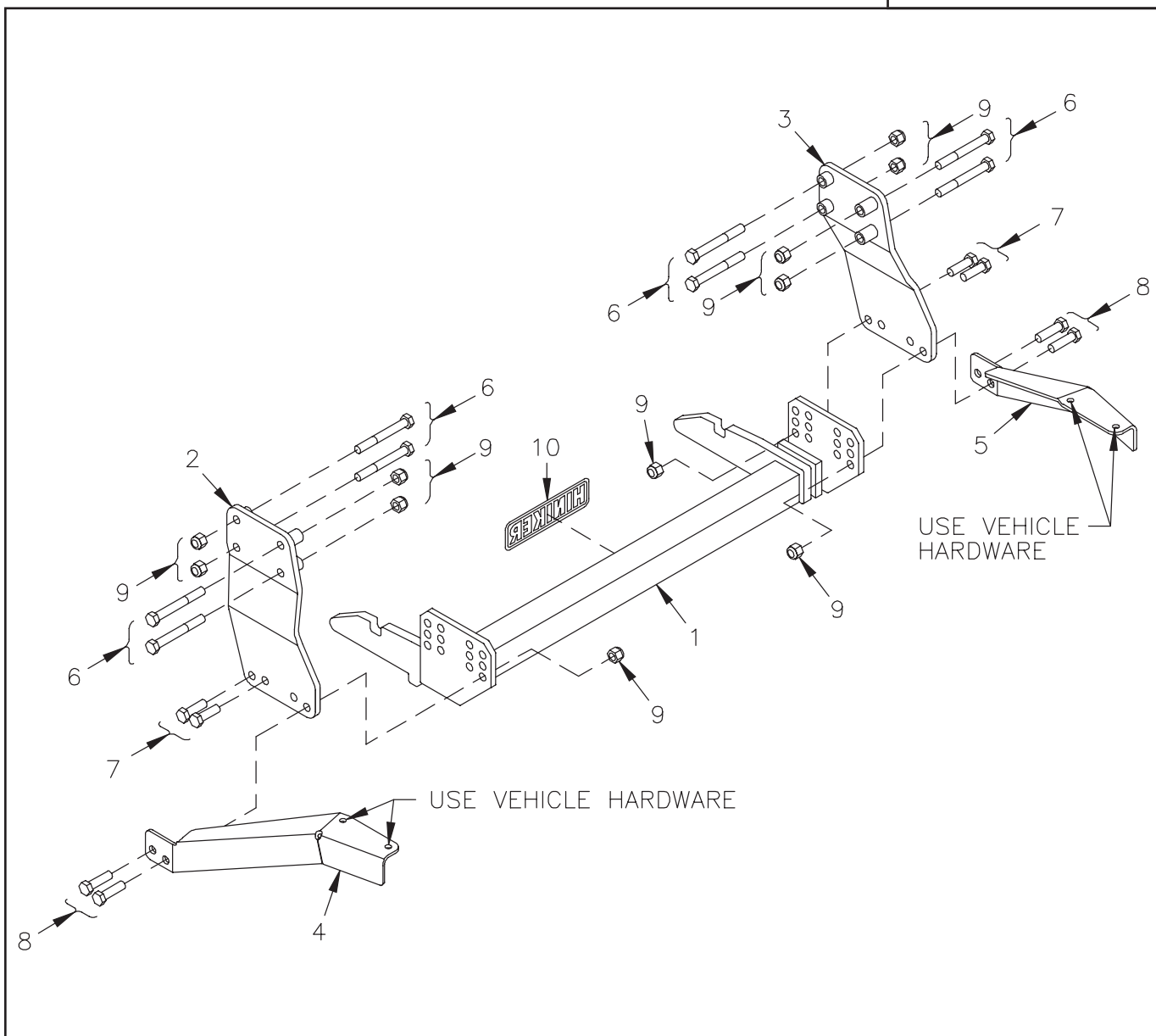

Mount Kit 25012122

DWG. NO. 5860

REF. NO.	PART NUMBER	DESCRIPTION	QTY.	REF. NO.	PART NUMBER	DESCRIPTION	QTY.
1	25012124	Prong Weldment	1	7	950-001-023	Hex Head Cap Screw 5/8-11 x 2 Gr. 5	4
2	25012125	LH Side Plate Weldment	1	8	950-001-185	Hex Head Cap Screw 5/8-11 x 2 1/4 Gr. 5	4
3	25012126	RH Side Plate Weldment	1	9	060756	Lock Nut 5/8-11 Nylon Insert	16
4	25012127	LH Rear Brace	1	10	25010008	Hiniker Decal	1
5	25012128	RH Rear Brace	1		25012130	Bolt Bag	1
6	061976	Hex Head Cap Screw 5/8-11 x 5 Gr. 8	8				

All hardware should be tightened only enough to ensure safety during assembly. Fully tighten all hardware after entire assembly is completed.

GRADE 5 TYPE B & F LOCK NUT TORQUE VALUES

Size	Ft-lbs.	N-m
5/16"	13-18	17-25
3/8"	23-33	31-44
1/2"	58-82	79-112
5/8"	117-165	158-223

GRADE 5 BOLT TORQUE VALUES*

Size	Ft-lbs.	N-m
1/4"	8-12	11-16
3/8"	29-41	39-56
1/2"	73-103	99-140
5/8"	146-206	198-279
* applications without lock nuts		

1. Remove the front bumper from the truck by unbolting the four fasteners attaching it to its mount brackets.
2. Remove the plastic shield from the passenger side of the truck by unscrewing the four fasteners attaching it to the vehicle frame rail. Save the fasteners for reinstalling the shield later.

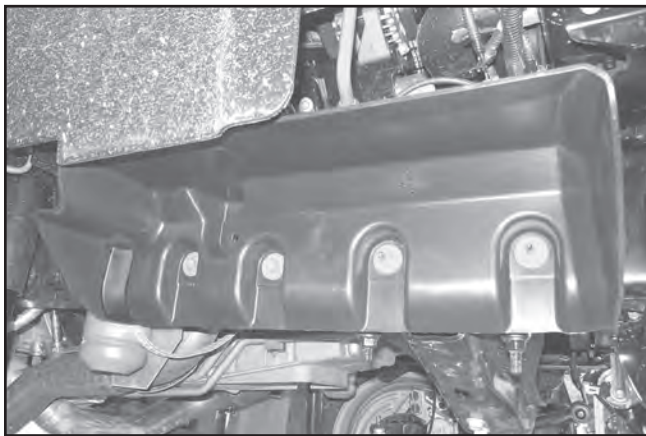

PHOTO NO. DCP0170

Saw away the lower rear portion of the plastic shield at the approximate dimensions shown to create clearance for the rear brace of the snowplow mount kit.

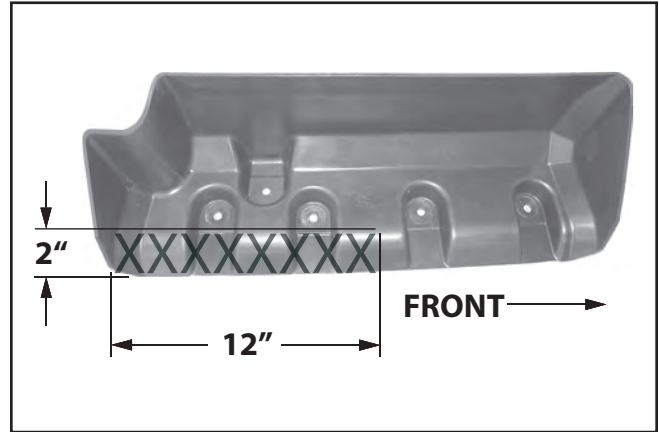

PHOTO NO. DCP0138

Set aside the shield for reinstallation later.

3. Remove four bolts from above the front spring shackle on each side of the vehicle. Fasteners will be replaced by hardware supplied in the kit.

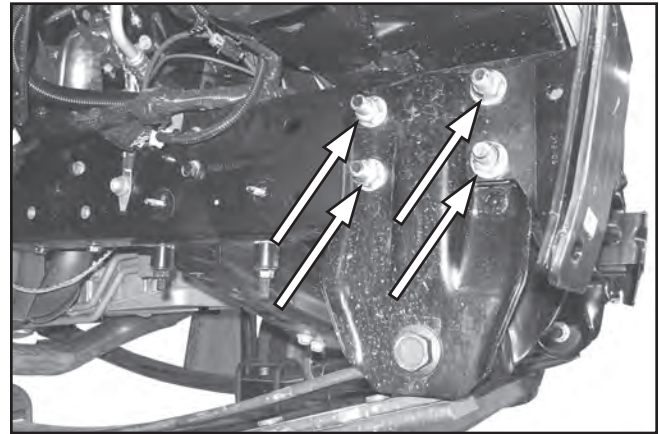

PHOTO NO. DCP0163

Assemble the LH and RH side plate weldments to the outside of the vehicle frame rails by inserting four 5/8 inch x 5 inch grade 8 hex bolts through the side plates, bumper brackets, vehicle frame and tow hooks, then securing the bolts with 5/8 inch lock nuts.

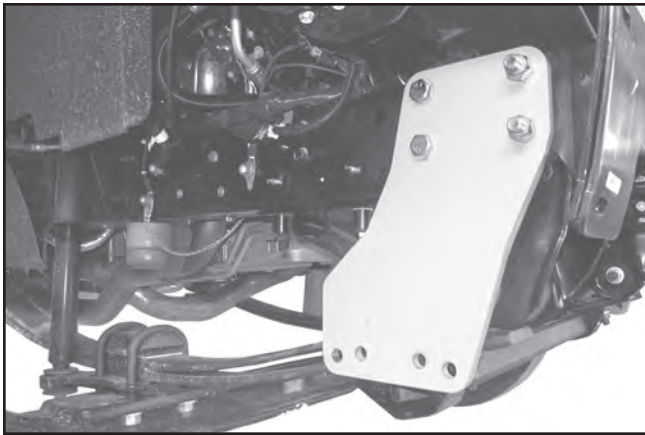

PHOTO NO. DCP0162

Note the direction of installation of the bolts in the photo to ease assembly.

4. Remove two bolts from the bottom of each vehicle frame rail and save for reinstallation.

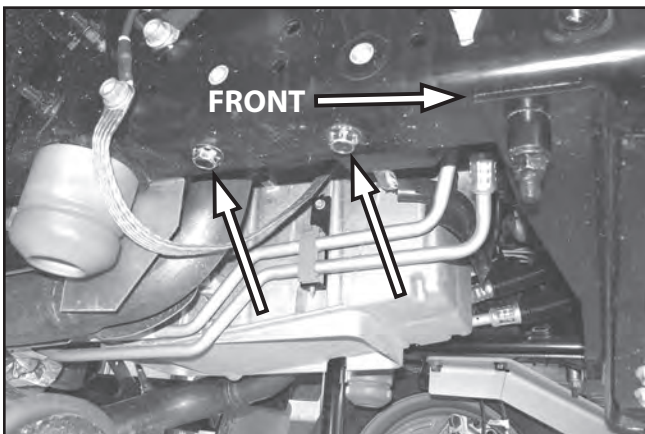

PHOTO NO. DCP0158

Lift the LH and RH rear braces to the vehicle so that rear holes in the braces match holes in the vehicle frame, and the front of the braces are outside of the front plate weldments.

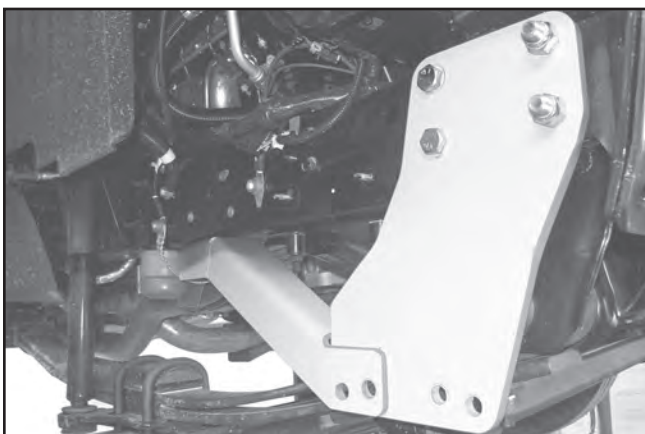

PHOTO NO. DCP0151

Reinstall bolts through the rear holes in the braces and into the vehicle frame to secure the assembly.

5. Bolt the mount plates of the prong weldment between the LH and RH side plate weldments, as follows:

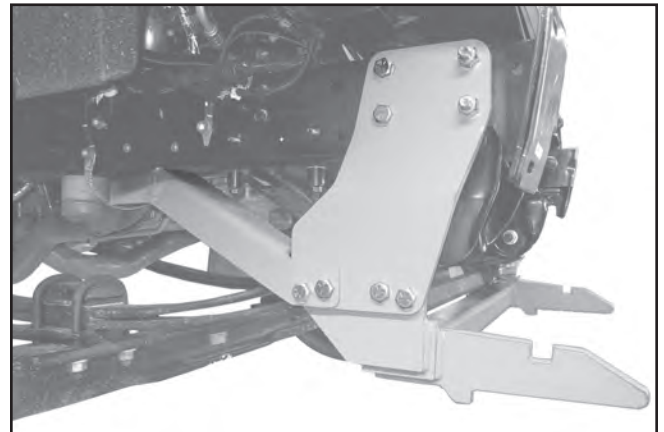

PHOTO NO. DCP0144

Insert 5/8 inch x 2 inch hex bolts through the two front holes of the side plates and prong plates.

Insert 5/8 inch x 2 1/4 inch hex bolts through holes in the rear braces, side plates and prong plates.

Secure the bolts with 5/8 inch lock nuts.

6. Finish installation of the mount by fully tightening the hardware. Tighten bolts into the vehicle frame first to draw components tight to the frame, then tighten the bolts fastening the prong plates.

Bottom edges of the prongs should measure about 10 inches above the ground when completed.

7. Reassemble the plastic shield that was modified in step 2 to the passenger side of the vehicle using the original hardware.

Reinstall the front bumper and fully tighten bumper hardware.