

Hiniker Company
 58766 240th St.
 P.O. Box 3407
 Mankato, MN 56002

VEHICLE INSTALLATION INSTRUCTIONS FOR:
 JEEP WRANGLER 4X4: 2007 & NEWER

INSTRUCTION SHEET NO: 25012563 Rev. A

December 8, 2010



IMPORTANT: Read the Snowplow Operator's Manual before assembling this kit.

REAR BALLAST - 300 lbs. when plow is attached. Secure Weight Behind Rear Wheels.

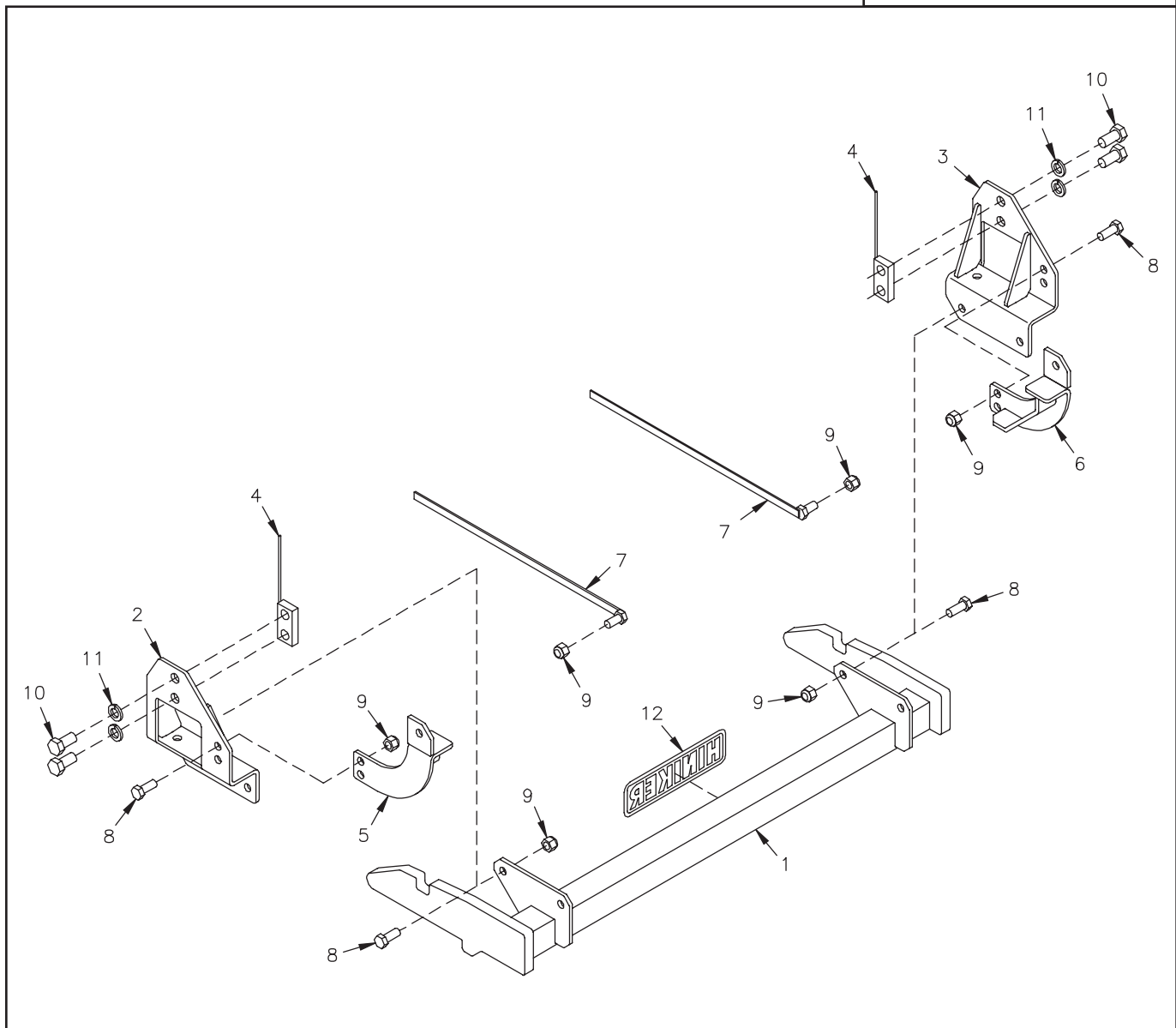

Mount Kit 25012566

DWG. NO. 6200A

REF. NO.	PART NUMBER	DESCRIPTION	QTY.	REF. NO.	PART NUMBER	DESCRIPTION	QTY.
1	25012556	Prong Weldment	1	8	950-001-111	Hex Head Cap Screw 1/2-13 x 1 1/4 Gr. 5	8
2	25012846	LH Front Bracket Weldment	1	9	951-003-009	Lock Nut 1/2-13 Nylon Insert	10
3	25012847	RH Front Bracket Weldment	1	10	031-06302	Hex Head Cap Screw 5/8-11 x 1 1/4 Gr. 5	4
4	25012848	Nut Bar Weldment	2	11	952-001-005	Lock Washer 5/8 Inch	4
5	25012559	LH Rear Bracket Weldment	1	12	25010008	Hiniker Decal	1
6	25012560	RH Rear Bracket Weldment	1		25012565	Bolt Bag	1
7	25012561	Bolt Weldment	2				

All hardware should be tightened only enough to ensure safety during assembly. Fully tighten all hardware after entire assembly is completed.

GRADE 5 TYPE B & F LOCK NUT TORQUE VALUES

Size	Ft-lbs.	N-m
5/16"	13-18	17-25
3/8"	23-33	31-44
1/2"	58-82	79-112
5/8"	117-165	158-223

GRADE 5 BOLT TORQUE VALUES*

Size	Ft-lbs.	N-m
1/4"	8-12	11-16
3/8"	29-41	39-56
1/2"	73-103	99-140
5/8"	146-206	198-279
* applications without lock nuts		

1. Remove the plastic splash shield from the front of the vehicle by prying loose six retainers. Save four retainers for reinstallation.

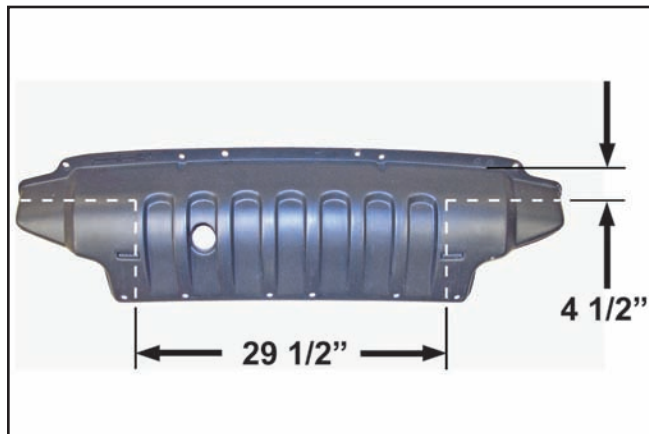

PHOTO NO. DCP1601A

Trim the shield at the approximate dimensions in the photo to provide clearance for mount kit components on the vehicle.

2. Disconnect wiring to the fog lights and other wiring to the front bumper. Unbolt the bumper from the vehicle by removing eight lock nuts and four spacer plates. Set the bumper and hardware aside for reinstallation.

3. On model year 2010 and newer vehicles, drill 21/32 inch diameter holes centered 1 1/2 inches above existing holes in the crossbeam support channels on both ends of the vehicle frame.

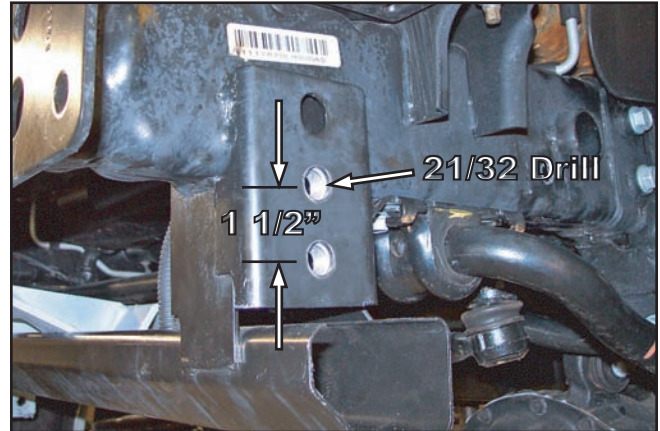

PHOTO NO. DCP1588A

Slip nut bar weldment from the mount kit down from the top behind the crossbeam support channels to match holes in the channels. Gently pry open the upper edge of the channels, if required, for nut bar clearance.

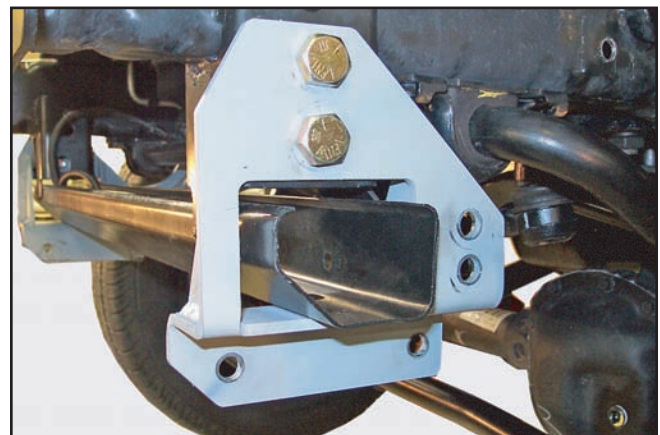

PHOTO NO. DCP1583

Fasten the LH and RH front bracket weldments to the vehicle with 5/8 inch x 1/4 inch hex bolts and lock washers.

4. Loosen the rear bolts of the vehicle's sway bar mounts about 1/2 inch to provide clearance for installing the bolt weldments.

Assemble the LH and RH rear brackets to the inside faces of the front brackets with two 1/2 inch x 1 1/4 inch hex bolts and lock nuts per side.



PHOTO NO. DCP1590

Push the back end of the rear brackets up tight to the vehicle frame before drilling 1/2 inch diameter holes into the frame through holes in the brackets.



PHOTO NO. DCP1581

Feed bolt weldments through the upper hole at the front of each frame rail, then out through the drilled holes and brackets. Install lock nuts on the bolts to secure the assembly.

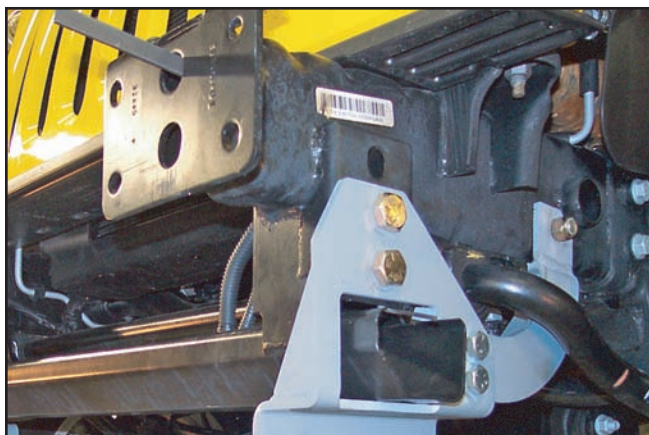

PHOTO NO. DCP1575

Use a hacksaw or cutting disc to trim bolt weldment handles flush with the front of the frame rails.

Retighten the rear bolts of the sway bar mounts.

5. Reassemble the front bumper to the vehicle, using eight original lock nuts and four spacer plates.

Reconnect wiring to the fog lights and secure all loose wiring to the bumper with plastic tie straps.

Lift the modified plastic splash shield up to align the four attachment holes along the front of the shield with holes in the vehicle. Fasten the shield to the vehicle with four original retainers.

6. Fasten the mount plates of the prong weldment between the front brackets with four 1/2 inch x 1 1/4 inch hex bolts and lock nuts.

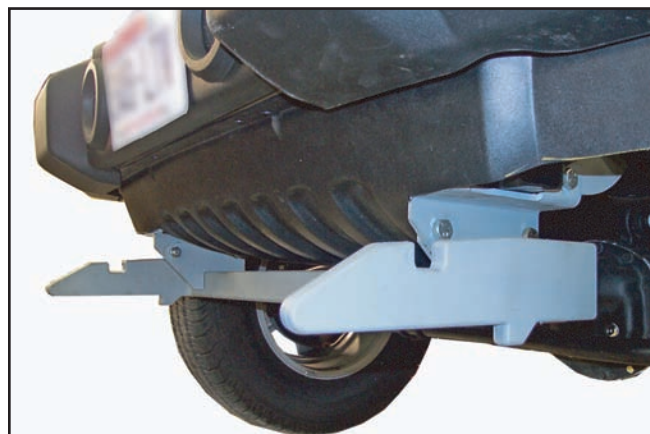

PHOTO NO. DCP1559

Bottom edges of the prongs should measure about 10 inches above the ground.

Fully tighten all hardware to specified torque values to complete assembly of the mount.