

VEHICLE INSTALLATION INSTRUCTIONS:

DODGE RAM 4X4: 2009 & Newer 1500

INSTRUCTION SHEET NO: 25012753

August 18, 2009



IMPORTANT: Read the Snowplow Operator's Manual before assembling this kit.

REAR BALLAST -
500 lbs. when plow is attached.
Secure Weight Behind Rear
Wheels.

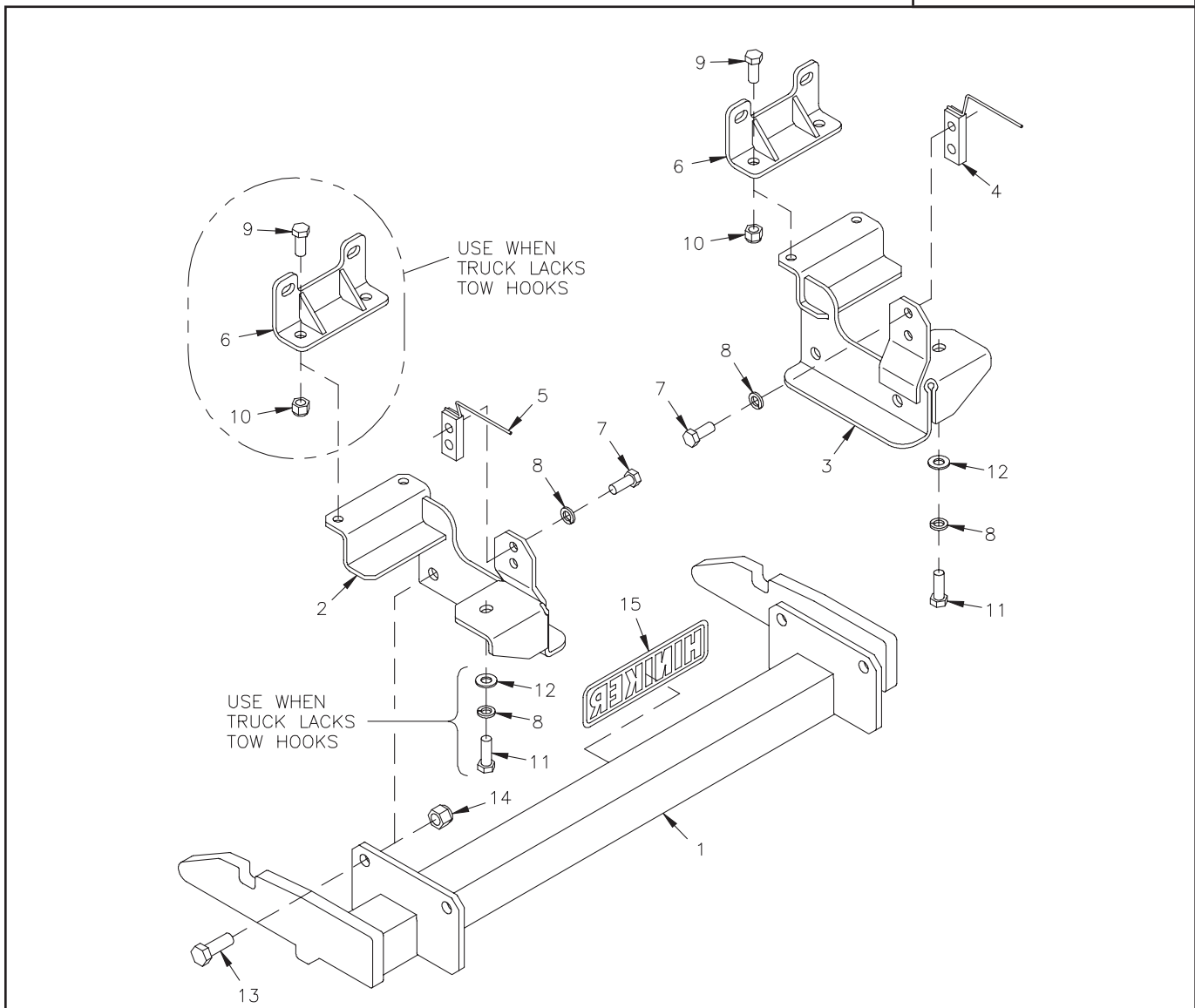

25012703 Mount Kit

DWG. NO. 6533

REF. NO.	PART NUMBER	DESCRIPTION	QTY.	REF. NO.	PART NUMBER	DESCRIPTION	QTY.
1	25012208	Prong Weldment	1	9	950-001-111	Hex Head Cap Screw 1/2-13 x 1 1/4 Gr. 5	4
2	25012738	LH Bracket Weldment	1	10	951-003-009	Lock Nut 1/2-13 Nylon Insert	4
3	25012739	RH Bracket Weldment	1	11	950-011-046	Hex Head Cap Screw M12 x 1.75 x 40 CL. 10.9	2
4	25012747	Nut Bar Weldment 1-3/8" Centers	1	12	952-003-004	SAE Flat Washer 1/2 Inch	2
5	25012746	Nut Bar Weldment 1" Centers	1	13	950-001-087	Hex Head Cap Screw 5/8-11 x 1 1/2 Gr. 5	4
6	25012750	Front Bracket Weldment	2	14	060756	Lock Nut 5/8-11 Nylon Insert	4
7	950-001-231	Hex Head Cap Screw 1/2-13 x 1 Gr. 5	4	15	25010008	Hiniker Decal	1
8	952-001-004	Lock Washer 1/2 Inch	6		25012752	Bolt Bag	1

All hardware should be tightened only enough to ensure safety during assembly. Fully tighten all hardware after entire assembly is completed.

GRADE 5 TYPE B & F LOCK NUT TORQUE VALUES

Size	Ft-lbs.	N-m
5/16"	13-18	17-25
3/8"	23-33	31-44
1/2"	58-82	79-112
5/8"	117-165	158-223

GRADE 5 BOLT TORQUE VALUES*

Size	Ft-lbs.	N-m
1/4"	8-12	11-16
3/8"	29-41	39-56
1/2"	73-103	99-140
5/8"	146-206	198-279

* applications without lock nuts

1. Remove the plastic air dam from the bottom of the front bumper. The air dam cannot be reinstalled when this mount kit is on the truck and should be returned to the vehicle owner for reinstallation if the mount is taken off the truck in the future.



PHOTO NO. DCP2563

To remove the air dam, first unbolt two screws from the ends of the dam, then use a side cutter or other means to pull the heads up on 13 push rivets before pulling the rivets out of the holes.

NOTE: For trucks without tow hooks, skip to step #3.

2. On one side of the vehicle at a time, remove the tow hook from the vehicle frame, then use the hardware to loosely bolt the LH and RH side bracket from the kit to the corresponding tow hook.

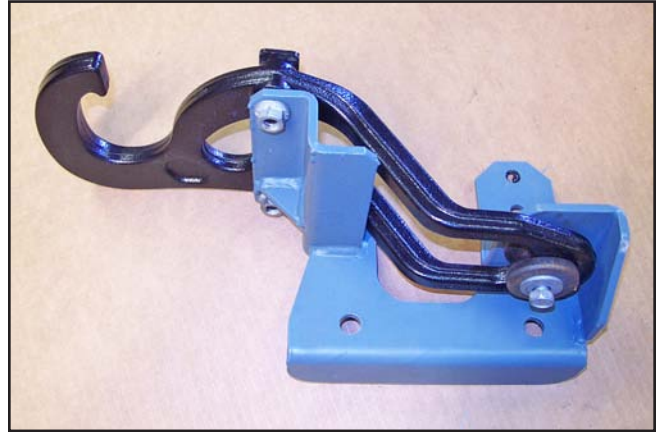

PHOTO NO. DCP2552

Reassemble the tow hooks to the vehicle frame by sliding the front two bolts forward into slots beneath the bumper brackets, then threading the rear bolts into the frame stubs.

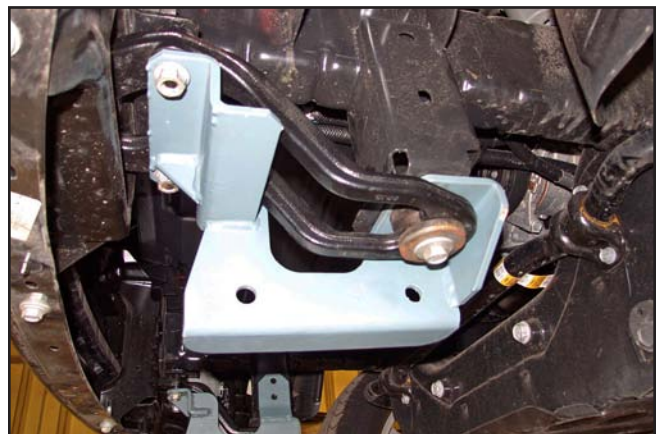
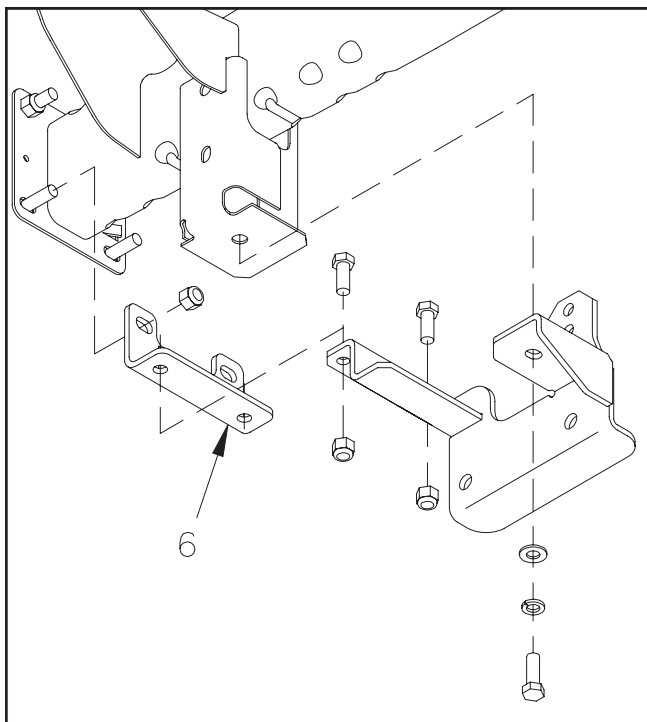

PHOTO NO. DCP2535

Tighten the hardware to draw brackets up to the frame.

Proceed to step #4.

3. On trucks without tow hooks, install front brackets from the kit, arrow #6, to the lower set of bolts through the two bumper brackets.



DWG. NO. 6534

Assemble the LH and RH side brackets to the front brackets, using 1/2 inch x 1 1/4 inch hex bolts and lock nuts.

Fasten the rear holes in each bracket to the vehicle frame stubs with M12 x 40 hex bolts, 1/2 inch flat washers and lock washers supplied in the kit.

4. Drill 1/2 inch diameter holes into the vehicle frame through the lower hole in the rear tab of each side bracket.

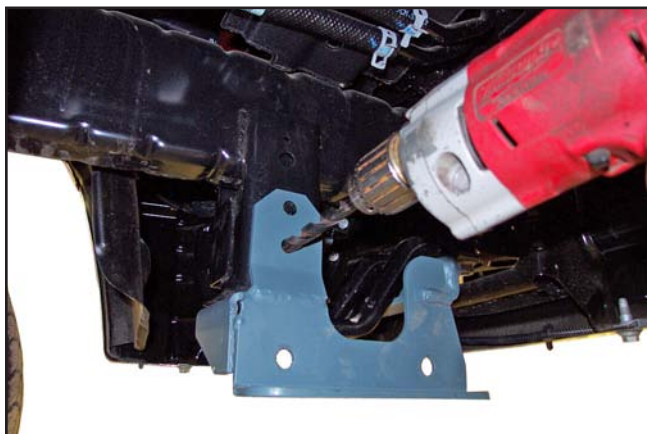

PHOTO NO. DCP2545

Bend handles on nut bars, as required, then insert nut bars through gaps in the upper

rear portion of the frame stubs to match holes in the side brackets.



PHOTO NO. DCP2542

Thread 1/2 inch x 1 inch hex bolts with lock washers into nut bars to secure side brackets to frame stubs.

5. Bolt the prong weldment to the LH and RH side brackets with 5/8 inch x 1 1/2 inch hex bolts and lock nuts.

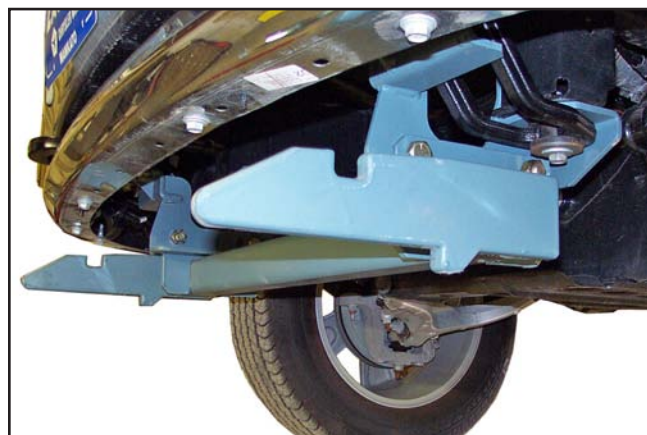

PHOTO NO. DCP2528

Bottom edges of the prongs should measure about 10 inches above the ground. Ideally, the prongs should lift the plow frame slightly when driving into the plow.

6. Fully tighten all hardware to specified torque values.