



**SKID STEER LOADER SNOWPLOW  
V-PLOW  
MODELS 29851, 29951**

**OPERATOR'S MANUAL**

DO NOT USE OR OPERATE THIS EQUIPMENT UNTIL THIS MANUAL  
HAS BEEN READ AND THOROUGHLY UNDERSTOOD

PART NUMBER 25013062

---

---

---



# TABLE OF CONTENTS

<b>25013062</b>	<b>4/11</b>	<b>MANUALS/25013062</b>
TO THE PURCHASER.....		2
SAFETY.....		3
OPERATING PROCEDURES .....		4
MAINTENANCE .....		6
TROUBLE SHOOTING .....		7
PLOW ASSEMBLY .....		8-10
HYDRAULIC DIAGRAMS.....		11
WIRING DIAGRAMS .....		12
SPECIFICATIONS.....		13
WARRANTY .....		14

## TO THE PURCHASER

This product is designed and manufactured to give years of dependable service when properly maintained and used for the purpose for which it is intended. Never allow anyone to operate this equipment until they fully understand the complete contents of this manual. It is the responsibility of owners who do not operate this equipment to ensure the operator is properly instructed and understands the contents of this manual. It is also the owner's responsibility to ensure that anyone operating this equipment is mentally and physically capable of so doing.

Important information is contained in this manual to help ensure safe and efficient operation.

If you have any questions about this manual, or the equipment discussed herein, contact your snowplow dealer.



**This is a safety alert symbol. It alerts an operator to information concerning personal safety. Always observe and heed these instructions, otherwise death or serious injury can result.**

All references to Left or Right are defined as viewing the plow from the cab of the machine.

This Operator's Manual is shipped with this equipment. Contact your dealer for additional copies.

Always obtain original factory service parts. Substitute parts could adversely affect equipment performance and warranty.

Check that your dealer has forwarded the delivery report form along with the plow identification number because it helps maintain maximum service and warranty benefits. This does not put you on any mailing list, and information thereon is not available to others.

Your plow's identification number decal is at location (1) in the following illustration.

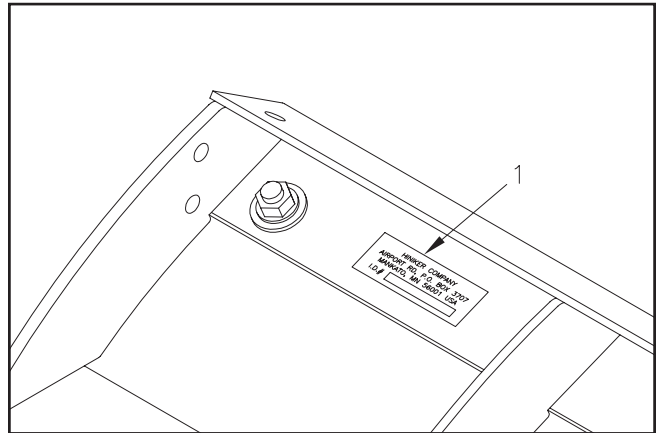

DWG NO. 6057

Record the following information for later reference when obtaining service parts:

Purchase Date \_\_\_\_\_

Purchaser's Name \_\_\_\_\_

Dealer's Name \_\_\_\_\_

Machine Serial No. \_\_\_\_\_

# SAFETY

---



This is a safety alert symbol. It alerts an operator to information concerning personal safety. Always observe and heed these symbols and instructions, otherwise death or serious injury can result.

Operator safety is a principle concern in equipment design and distribution. However, many accidents occur because a few seconds of thought, and a more careful approach to handling, were ignored. Accidents can be avoided by knowing and following the precautions cited in this manual.

## GENERAL SAFETY

1. Read this manual thoroughly. Make sure the operator understands it and knows how to operate this equipment safely. This equipment can kill or injure an untrained or careless operator and bystanders. If you sell this equipment, ensure the new owner acknowledges receipt of this manual.
2. This manual **Does Not** instruct the operation or maintenance of the skid steer loader. Obtain training on control and function of the skid steer loader from your loader dealer.
3. This plow is intended for plowing snow only. Plowing gravel, rocks, etc., or using the plow for any purpose other than plowing snow could result in harm to the operator or bystanders or cause damage to the plow, and will void the warranty.
4. Do not attempt to handle or service this equipment, or direct others to do the same, unless you know how to do it safely and have the proper tools for the job.
5. Do not service or otherwise handle a plow in the raised position unless it is securely blocked against unexpected falling.
6. Keep hands, feet, hair, and clothing away from moving parts.
7. Do not alter the equipment to the extent of compromising safety or performance.

## BEFORE OPERATION

1. Discipline yourself to visually check for worn, damaged or cracked parts before starting use. Replace these with genuine factory service parts.
2. Escaping hydraulic oil under pressure can penetrate the skin, causing serious injury.

Do not use your hand to check for leaks. Use a piece of paper or cardboard to find suspected leaks. Tighten all connections before pressurizing hydraulic lines. If fluid is injected into the skin, get medical attention immediately to prevent serious infection.

3. Check all controls and operating functions of the machine in a safe area before starting to work.

## DURING OPERATION

1. Always wear the seat belt and lower the seat bar, if equipped, when operating the loader.
2. Make sure all controls are in the neutral position before starting the loader.
3. Ensure everyone is clear of the machine, especially away from blind areas of the operator, before actuating hydraulics or operating this equipment.
4. Do not plow snow at excessively high speeds.
5. Avoid hitting objects that will damage your plow.
6. Set the brakes and stop the loader's engine before adjusting or servicing your plow.

## AFTER OPERATION

1. Park the plow on a solid, level surface.

# OPERATING PROCEDURES

## ATTACHING THE PLOW



**IMPORTANT:** To prevent damage to snowplow components, skid steer loaders that drive this plow must be equipped with a relief valve in the auxiliary hydraulic system set at 2100 psi.

Mount the plow on the skid steer loader by driving the loader into the mount frame, then set the brakes and relieve hydraulic pressure before exiting the cab. Secure the plow frame to the loader as instructed in the loader manual. Make sure all latches are fully locked in place to prevent the plow from detaching.

Clean quick couplers of dirt before making hydraulic connections. Make sure quick couplers are fully engaged. If quick couplers do not fully engage, check that the couplers are the same size and type. Check also to see that hydraulic pressure has been relieved. See your loader or attachment dealer for coupler information.

Clean electrical connections then check that the pins and receptacles are aligned before plugging the connector on the plow into the connector on the loader.

Test the angling and wing functions in a safe area before using the plow.

## CONTROLLING THE PLOW FUNCTIONS

Raise and lower the plow by operating the loader arms as you would for any other attachment. Avoid tipping the mount plate forward to apply down pressure on the plow.

Wing functions are controlled by directing oil through the auxiliary hydraulic ports on the skid steer loader while pushing on one or both of the round button switches.

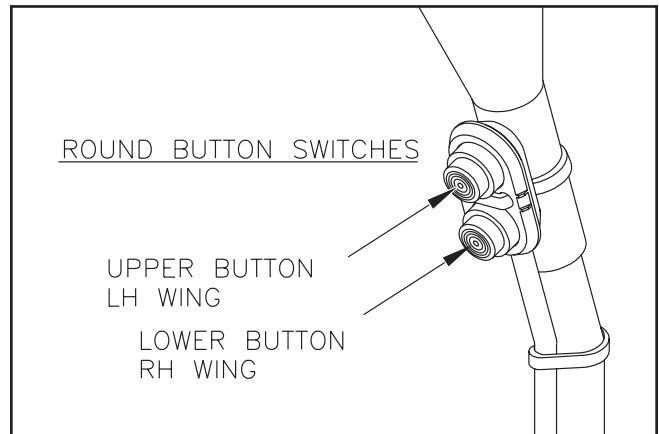

DWG NO. 5144

Each button switch controls the extension and retraction of one wing cylinder. Reversing oil flow direction on the loader while holding the same button results in opposite function of the wing.

Holding both buttons simultaneously will move the plow into the V or scoop position, depending on the oil flow direction.

If the plow functions opposite from what is expected, switch couplers on the two feed hoses that connect to the loader. Likewise, switching electrical connections between the two solenoid coils on the manifold assembly will change control of the left and right wing functions between upper and lower button switches to suit user preferences.

To hold a wing at an intermediate position between full forward or full back, release the hydraulic controller, then release the round button switch.

The plow wings will move more freely if the wing functions are done with the plow raised to avoid resistance from the ground.

## TRANSPORTING THE PLOW

Raise the blade to a position where it does not block your view forward. Transport the plow with hydraulic flow off or in neutral to prevent accidental lowering of the plow. Never adjust the blade position while driving.

## PLOWING SNOW



**WARNING: Always wear the seat belt and lower the seat bar, if equipped, when plowing snow. Sudden contact with a hidden object can result in serious personal injury.**

Inspect areas to be plowed before snowfall for potential hazards, and mark obstructions with stakes that will be seen when snow covers the ground. Identify any emergency equipment and utility outlets that may need to be cleared in the event of a storm. Prepare a plan beforehand for clearing snow from tight or enclosed areas and locate sites for stacking snow.

Adjust the skids at the back of the moldboard according to the surface to be plowed. The bottom of the skids should be about 1/2" below the cutting edge when plowing gravel roads or lots. Skids should be even with the cutting edge on hard surfaces such as asphalt or concrete.

Level the plow on the ground in the scoop or V-position by angling the mount plate on the skid steer loader to maximize cleanup while plowing.

Set the loader lift arms into the float mode so the plow can follow the contour of the ground and clean up low areas while plowing snow.

Always plow snow as it is accumulating. Wet snow may weigh about 12 pounds per cubic foot. The weight of snow being pushed by your plow may increase to several tons.

Allowing snow depth to grow to unmanageable levels can cause difficult removal problems and can be costly in terms of wear on equipment.



**WARNING: Serious personal injury can result from plowing at excessive speeds, as well as costly damage to equipment and property, if an obstruction is encountered while plowing. Do not exceed 10 mph while plowing.**

Begin clearing large lots by putting the plow in the V-position and creating a single path. Roll snow to the outer edges of the lot by taking successive passes with the blade angled, or put the plow in the scoop position and push snow to the end of the lot.

Break up hard snow banks with the plow in the V-position.

When plowing very deep snow, it may be necessary to raise the blade and shear off layers of snow until a working area is cleared. Work small areas in multiple passes to push snow to outer edges. Generally, 6 inch snow can be plowed with the entire blade width; 9 inch snow with 3/4 of the blade width; 12 inch snow with 1/2 of the blade width. Local conditions will determine how much work can be done before stalling or getting stuck.

## REMOVING THE PLOW

Park the plow on a solid level surface with the wings in the V-position.

Lower the blade to the ground, relieve hydraulic pressure and set the brakes on the loader.

Uncouple the hydraulic feed lines from the loader and unplug the electrical connector by pulling straight apart. Do not twist the connector, as twisting will damage the connector pins or the wiring harness. Replace any dust caps at this time.

Unlatch the attachment mechanism at the front of the loader then slowly drive the loader back away from the plow.

# MAINTENANCE



**WARNING: Do not service or otherwise handle a plow in the raised position unless it is securely blocked against unexpected falling.**

Dependable snowplow operation is the result of following good maintenance procedures. Inspect your plow frequently to ensure that all parts are working smoothly, and develop a schedule for maintenance at required intervals.

## GENERAL

Wash salt and dirt off the plow before storage. Touch-up any chips or scratches in the paint and apply a light coating of grease to extended cylinder rods to prevent corrosion.

## MECHANICAL COMPONENTS

Prior to the operation of a new snowplow, or one which has been stored, inspect all hardware and verify proper torque on all bolts and nuts in accordance with the recommended torque specifications.

### GRADE 5 TYPE B & F LOCK NUT TORQUE VALUES

Size	Ft-lbs.	N-m
5/16"	13-18	17-25
3/8"	23-33	31-44
1/2"	58-82	79-112
5/8"	117-165	158-223

### GRADE 5 BOLT TORQUE VALUES\*

Size	Ft-lbs.	N-m
1/4"	8-12	11-16
3/8"	29-41	39-56
1/2"	73-103	99-140
5/8"	146-206	198-279

\*applications without lock nuts.

Loose bolts can cause hole elongation and part failure resulting in dangerous operating conditions and equipment breakdown.

Check all hardware periodically during the plowing season and keep tightened to specified torques. Replace worn bolts and lock nuts with grade 5 bolts and equivalent type B or type F lock nuts. Type B lock nuts are plain hex; type F lock nuts are flanged hex.

Inspect wear of the cutting edges before every plowing season and frequently throughout the season. Replace cutting edges before wear is into wing or mast sections to avoid damage to these components.

## ELECTRICAL MAINTENANCE

Periodically check all electrical connections for proper fit and remove any contamination that may be present.

To prevent contamination always place dust caps on connectors when not in use. This is particularly important when the plow is being stored. The use of dielectric grease is recommended to reduce corrosion of the contacts and to make connecting and disconnecting easier.

Before each season check loader battery and electrical system for proper operation. A weak battery, dirty terminals, or faulty charging system may cause improper operation.

# TROUBLE SHOOTING

## GENERAL

- |   |   |
|---|---|
| <p>1. Check to see that the plow and loader are wired correctly with clean, tight connections at the battery. Check for proper voltage.</p> <p>2. Check that hydraulic quick couplers are fully engaged and electrical connection is tight at the loader.</p> | <p>3. Check the hydraulic oil level in the skid steer battery.</p> <p>4. Check for external leakage at cylinders, hoses and the valve manifold.</p> |
|---|---|

PROBLEM	POSSIBLE CAUSE	REMEDY
1. Hydraulic cylinder does not function or functions slowly when hydraulics are activated.	<p>A. Weak or defective loader battery.</p> <p>B. Oil level low.</p> <p>C. Hydraulic connection leak.</p> <p>D. Solenoid valve not opening properly.</p>	<p>A. Charge or replace battery.</p> <p>B. Add oil (do not overfill).</p> <p>C. Tighten or redo connection.</p> <p>D. Replace valve.</p>
2. Plow angles opposite expected direction.	A. Feed hoses reversed.	A. Switch quick couplers on feed hoses.
3. Oil leaks from cylinder(s).	A. Defective cylinder.	A. Repack or replace cylinder.
4. Plow wings relieve too easily or too difficulty while plowing.	A. Relief pressure set too low or too high.	A. Have relief pressure adjusted by snowplow dealer.
5. Plow does not clean-up snow from low areas.	A. Loader arms not in float mode.	A. Loader arms should be in the float mode.
6. Battery goes dead with power on the loader.	A. Short in wiring.	A. Locate and repair.
7. Hydraulic quick couplers don't connect.	<p>A. Wrong size or type of couplers.</p> <p>B. Oil pressure in loader lines.</p>	<p>A. Verify matching couplers.</p> <p>B. Relieve hydraulic pressure in loader.</p>

## V - PLOW ASSEMBLY

### GENERAL INFORMATION



**WARNING:** To prevent personal injury or death, be certain to keep clear of any parts that may drop when removing bundling straps, wires or brackets. Support heavy sections with hoist or blocks before removing wires or straps.

**IMPORTANT:** To prevent damage to snowplow components, skid steer loaders that drive this plow must be equipped with a relief valve in the auxiliary hydraulics system set at 2100 psi.

Be certain that hydraulic hoses and electrical wires are safely routed and allow full motion of moving parts. Secure loose hoses and wires with plastic tie straps.

In the following instructions, left and right machine references are defined as being viewed from the cab of the loader.

### QUICK COUPLERS

Select and install hydraulic quick couplers and adapter fittings on the V-plow feed lines according to the size and type (i.e. flat face or poppet style) of couplers on the skid steer loader.

Hoses supplied on the V-plow have 9/16-18 JIC female swivel ends for 9/16-18 JIC male adapters.

### PLOW ASSEMBLY

1. Lift the snowplow moldboard assembly to a clear level working area by hooking hoist chains through the two holes in the top plate of the center mast. The hoist should be capable of lifting at least 1,000 lb. loads.

Remove shipping straps from between the center mast and lugs on the back of the moldboard assembly. Discard the straps and save the hardware for reinstallation.

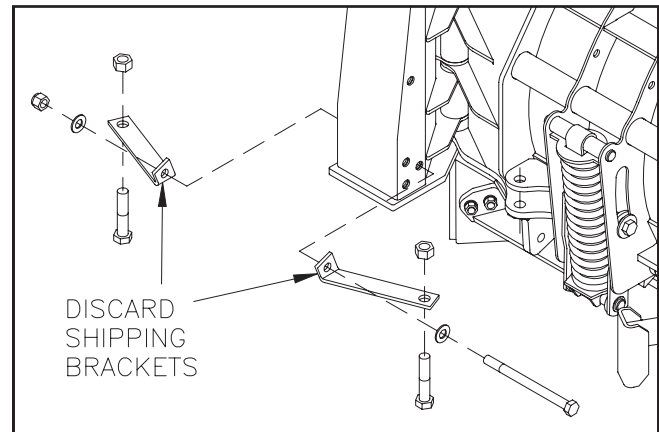

DWG NO. 6706

Remove two 5/8 inch x 8 inch hex bolts from the front of the pushframe and save the hardware for reinstallation.

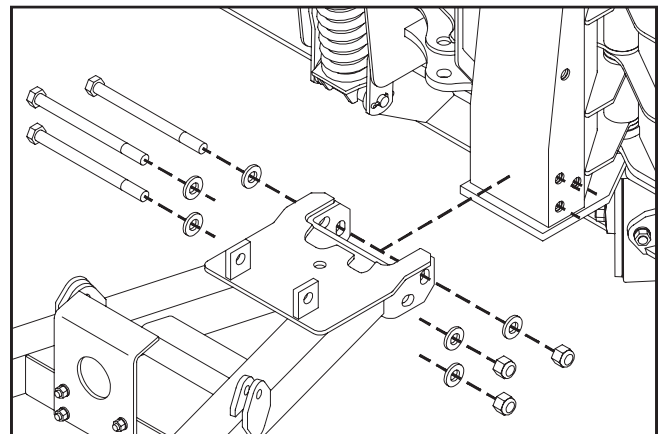

DWG NO. 6707

Move the frame assembly to the back of the moldboard assembly and align three sets of holes at the front of the frame assembly with holes through the moldboard center mast.

Place a flat washer onto the three hex bolts before inserting them through the holes. Secure the bolts with flat washers and lock nuts.

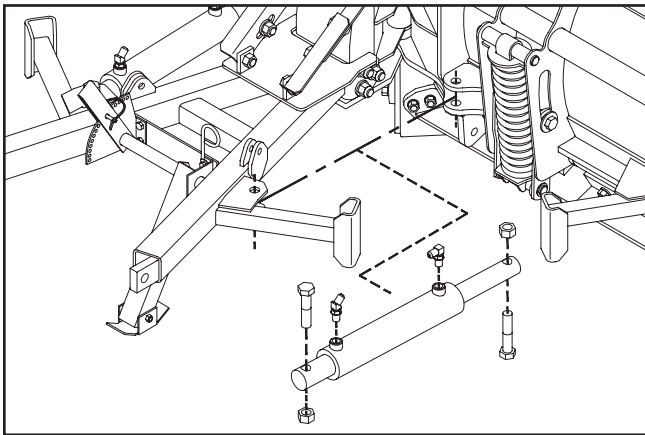

DWG NO. 6708

Snip the plastic ties holding the hydraulic cylinders to the frame assembly, then extend the cylinder rods to lugs on the back of the moldboard. Pin the cylinder rods between lugs, using 3/4 inch x 3 1/2 inch hex bolts and lock nuts removed earlier.

- Loosen the nuts and bolts fastened through the angle braces at the front of the frame assembly.

Remove the 7 inch long bolt and lock nut, then swing the braces up to insert the bolt through holes in the braces and center mast. Thread the lock nut back onto the bolt to secure the assembly.

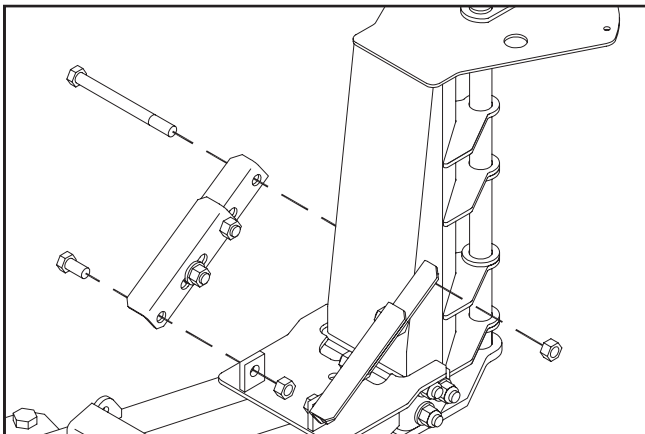

DWG NO. 6060

Rotate the frame assembly up to a position where the push frame is perpendicular to the vertical pin through the center mast, then fully tighten all hardware between the center mast and push frame.

- Clean and dry the back side of the moldboard in the area shown before applying the logo decal supplied with the plow.

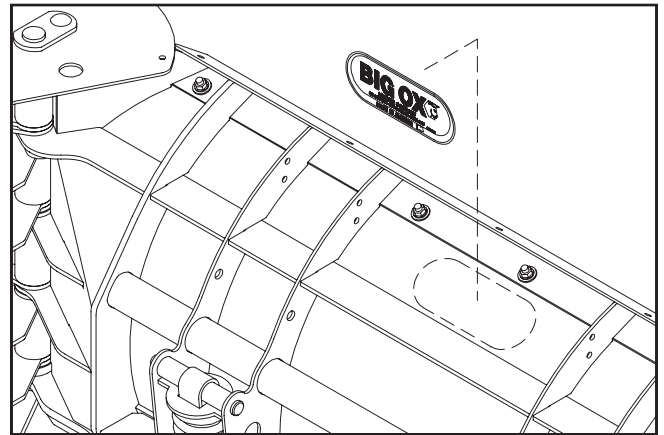

DWG NO. 6709

The moldboard must be at room temperature for the decal to adhere properly.

### ELECTRICAL WIRING



**IMPORTANT:** Damage to the wiring harness will occur if adequate cable length is not provided to allow for full motion of the loader arms. Use plastic tie straps to secure the wiring harness to the loader arm immediately adjacent to the loader arm pivot point.

Locate the electrical control cable supplied with the snowplow. It has a square four-pin weather pack connector on the first end, two ring terminals on the second end, and a single push button switch on the third end. Refer to drawing number 4285.

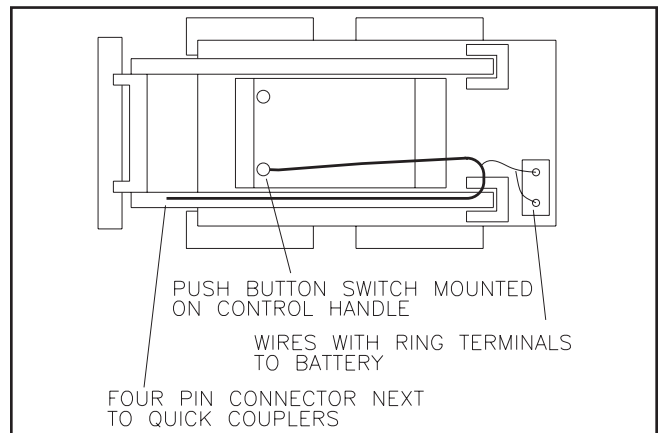

DWG NO. 4285

Locate the square four-pin connector next to the hydraulic quick couplers.

Route the cable from the square connector along the skid-steer arm to the pivot point of the arm and fasten with the supplied plastic ties. It is especially important to leave adequate cable at the pivot point to allow for arm movement.

Next, the switch cable needs to be routed into the cab. Attach the switch to the control arm using a plastic tie as shown in drawing number 5143.

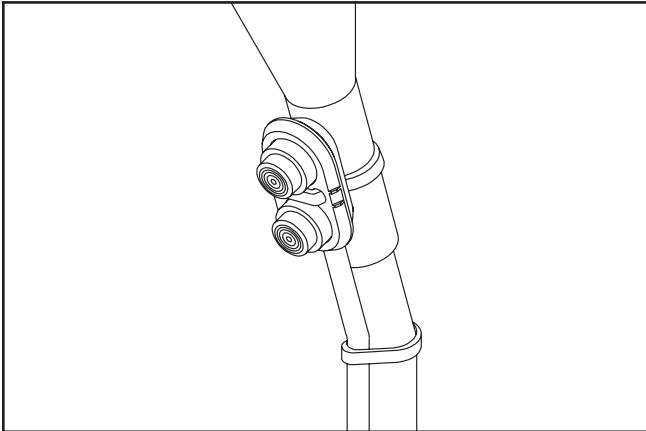

DWG NO. 5143

The third length of the cable must be routed to the battery. Connect the red fused wire with a ring terminal to the positive post of the battery and the black wire with a ring terminal to the negative post of the battery.

Route all wires away from hot or moving parts, securing with plastic ties to prevent damage.

The wiring on the plow comes preinstalled. The connections to the solenoids should be firmly seated.

Connectors on the solenoids are interchangeable, and can be reversed to change control of the left and right wing functions between the two button switches to suit user preferences.

Refer to Operating Procedures section for instructions for attaching the plow to the loader and operating the plow. Test that all functions are working properly and that cabling is not being stretched or pinched.

# HYDRAULIC DIAGRAM

## V-PLow VALVE MANIFOLD

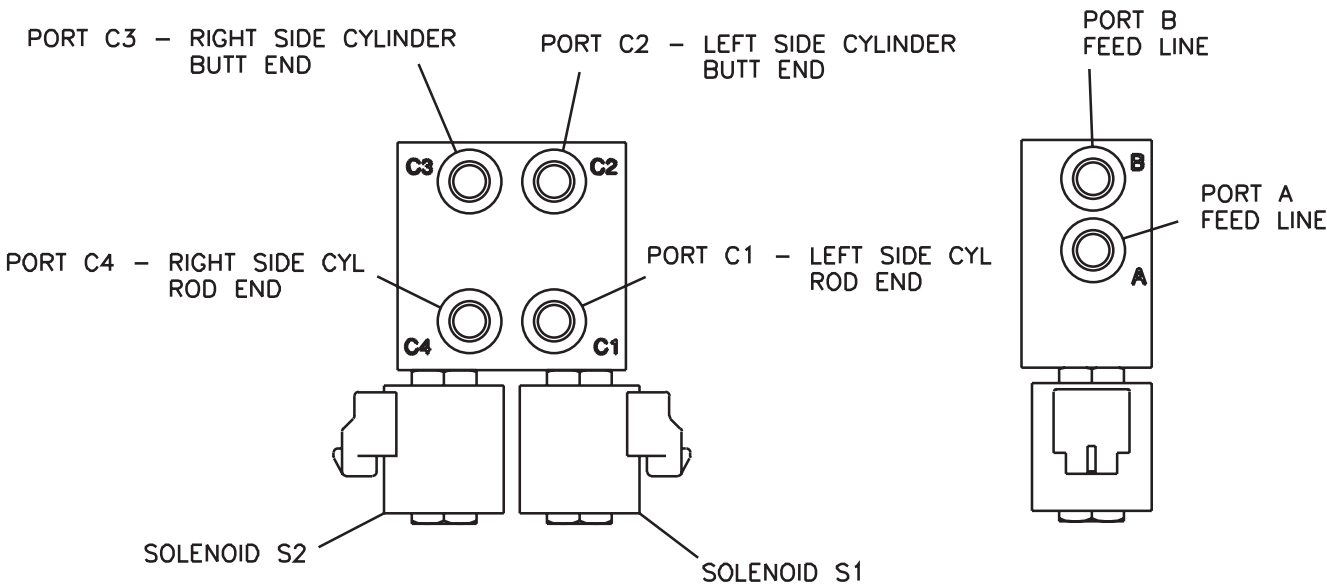

## VALVE MANIFOLD HYDRAULIC CIRCUIT DIAGRAM

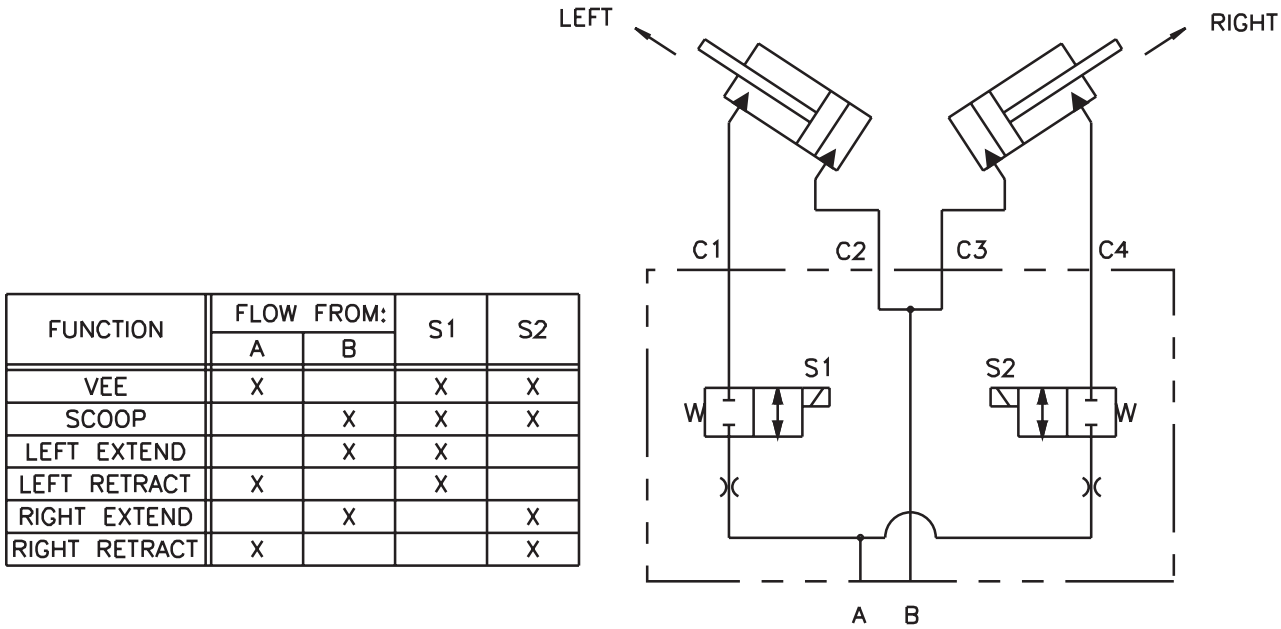

# WIRING DIAGRAM

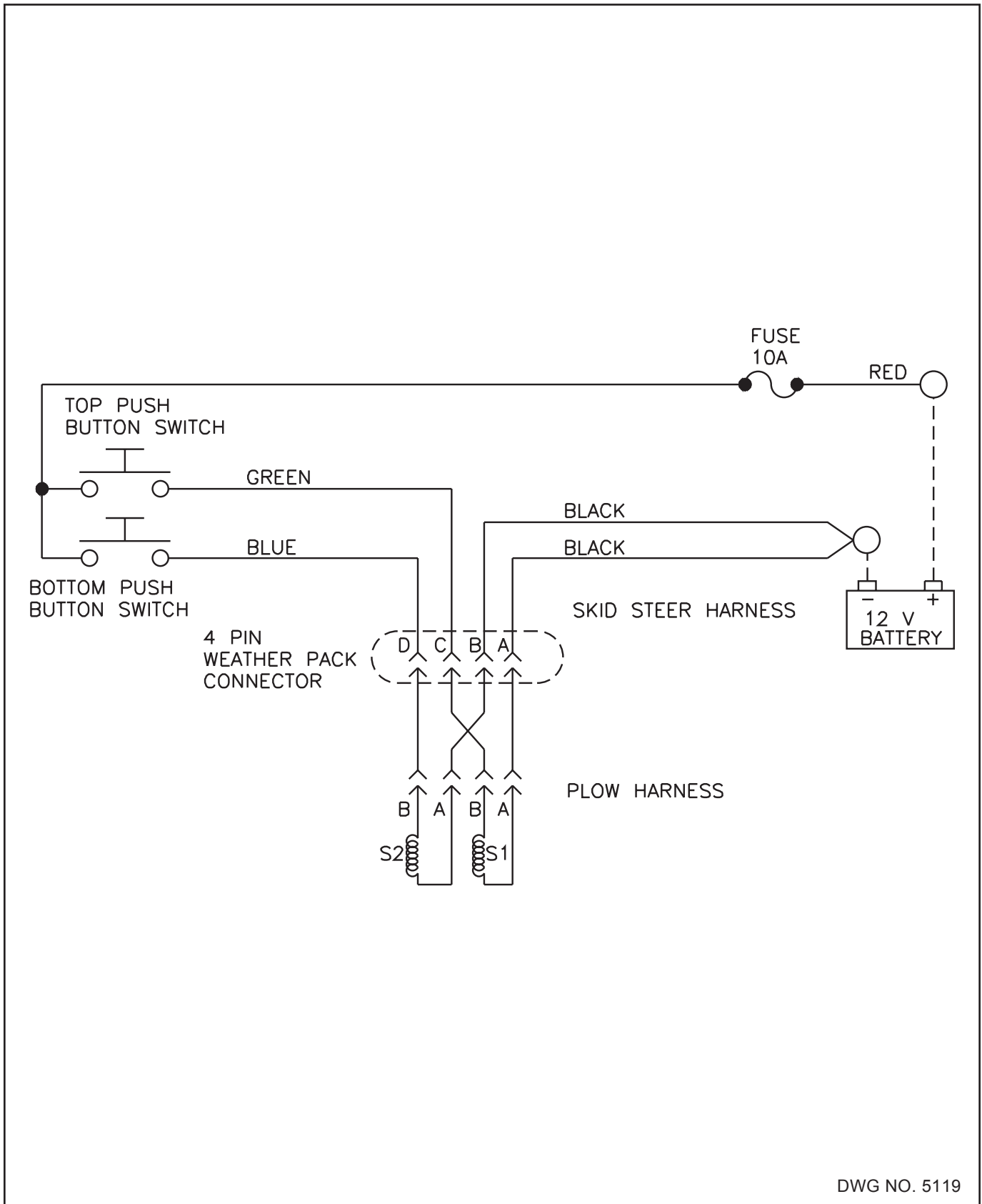

## SPECIFICATIONS

	8 1/2' Plow	9 1/2' Plow
Plow Width	8' 6"	9'6"
Plow Width - "V" Position	7' 9"	8'8"
Plow Width - Scoop Position	6' 11"	7'10"
Plow Width - Angled 30°	7' 4"	8'3"
Blade Height	30"	
Cutting Edge	3/8" x 6" 1084 Steel	
Weight	776 lbs.	822 lbs.
Wiring Harness Fuse	10 amp	

# WARRANTY

## SKID STEER SNOWPLOW LIMITED WARRANTY

The only warranty Hiniker Company (Hiniker) gives and the only warranty that any Hiniker dealer is authorized to give on behalf of Hiniker is as follows: **(NO EMPLOYEE OR REPRESENTATIVE IS AUTHORIZED TO CHANGE THIS WARRANTY IN ANY WAY OR GRANT ANY OTHER WARRANTY.)**

Hiniker warrants to the original purchaser of a Hiniker snowplow that Hiniker will repair or replace any defects in material and workmanship that occur within one year from date of retail delivery.

Hiniker's obligation and liability under this warranty is expressly limited to repairing or replacing, at Hiniker's option, at an authorized Hiniker dealer location, the defective parts at no charge to the original purchase. **HINIKER MAKES NO OTHER WARRANTY, EXPRESS OR IMPLIED AND MAKES NO WARRANTY OF MERCHANTABILITY OR OF FITNESS FOR ANY PARTICULAR PURPOSE.**

**HINIKER'S OBLIGATION UNDER THIS WARRANTY SHALL NOT INCLUDE ANY TRANSPORTATION CHARGES TO OR FROM THE AUTHORIZED HINIKER DEALER LOCATION OR ANY LIABILITY FOR INCIDENTAL, INDIRECT OR CONSEQUENTIAL DAMAGE OR DAMAGES OF ANY KIND FOR LOST PROFITS OR DELAY.** If requested by Hiniker, products or parts for which a warranty claim is made are to be returned freight prepaid to our factory. Any improper use, operation beyond rated capacity, substitution of parts not approved by Hiniker Company, or any alteration or repair in such manner as in our judgment affects the product materially and adversely shall void this warranty.

Hiniker reserves the right to make improvements or changes to any of its products without notice. Such improvements or changes shall not trigger any obligation by Hiniker to update, modify or change any products previously sold by Hiniker.

HINIKER does not warrant the following:

1. Used products.
2. Any product that has been repaired, modified or altered in a way not approved by Hiniker Company.
3. Depreciation or damage caused by normal wear, lack of reasonable and proper maintenance, failure to follow Operators Manual Instructions, misuse, lack of proper protection during storage, or accident.
4. Parts replacement and service necessitated by normal wear or maintenance including, but not limited to, cutting edges, hoses, snowplow skid shoes, and hardware.
5. Paint finish damage caused by normal wear.

Hiniker does not assume any liability for any damage to a skid steer unit resulting from the attachment or use of a Hiniker snowplow. Attachment of a Hiniker snowplow to skid steer unit is at the risk of the purchaser.

It is the responsibility of the original snowplow purchaser to verify the original date of purchase.

A DELIVERY REPORT FORM must be filled out and received by Hiniker with 30 days of retail delivery at the address below to initiate the warranty coverage.

**HINIKER COMPANY**  
**58766 240th St.**  
**P.O. Box 3407**  
**MANKATO, MN 56002-3407**  
**PHONE (507) 625-6621 -- FAX (507) 625-5883**  
**[www.hiniker.com](http://www.hiniker.com)**

